



BOSNAX (THAILAND) CO.,LTD.

บริษัท บอสแนกซ์ (ประเทศไทย) จำกัด

141 Phiboonwattana, Rama 6 Rd., Samsennai, Payathai, Bangkok 10400

Tel : 0-2271 2984 (Auto) Fax : (662) 618-5482 E-mail : marketing@bosnax.com

# CL-CLAD®



The new reliable cladding technology.  
 Brazing process patented by Carbone Lorraine

- Need thinner base plates and clad material than Explosion Clad.
- Resistant to full vacuum. With the same vacuum and flexion resistance as Explosion Clad.
- >>>> Less Expensive Solution in Same Quality as Explosion Clad.

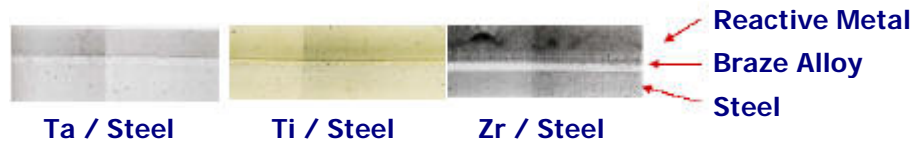

## Clad material :

- Tantalum (Ta)
- Titanium (Ti)
- Zirconium (Zr)

## Base Plate material :

- Carbon Steel
- Stainless Steel

Plates size up to 4500x2500 mm.

## Clad thickness :

Minimum :	0.5 mm. (instead of 1 mm. of Explosion Clad)
Maximum :	any thickness on request, no maximum limit.
Standard :	Tantalum : 0.7mm. (1mm. on request for safety) Ti and Zr : 1mm.

## Base plate thickness :

Minimum : 3mm.  
(instead of 10-15 mm. of Explosion Clad)  
 Actual : as per structural design.

## CL-CLAD plate properties

 Bending test	CL-Clad	ExplosionClad
Bending Radius	30 mm	30 mm
Bond fault (%)	<1	<1
Shear strength (MPa)	140	140
Thermal shock 220°C → 20°C	Pass	Pass
Vacuum resistance at 220°C	Pass	Pass

### Products :

- Reactor
- Vessel
- Column
- Tank
- etc.



### Main advantages :

- Better thermal conductivity
- The heat transfer between the reactor and jacket is more efficient.
- Life time improvement
- Good resistance to thermal shock
- Good resistant to mechanical shocks
- Good resistant to corrosion
- Good resistant to high temperature
- Good resistant to electrostatic shocks
- Good resistant to tightening
- High Strength
- Better flexibility
- No risk of cracks
- Heavy metals free
- More SAFETY
- Reduce costs
- Low MAINTENANCE COSTS
- Less expensive.



## Advantages of CL-Clad compared to glass lining :

- **Glass-lined equipment**
  - **Very fragile, less resistant against thermal shock**
    - Regular maintenance required
    - Potential safety concerns
    - Low heat-up and cool down → long process cycles
    - Requirement for many clamps to close the reactor and ensure the tightness
  - **Low thermal conductivity**
    - Low Heat transfer
    - Less precise control of the reaction temperature

## Reactor range :

Carbone Lorraine proposes a complete range of reactors produced with CL-Clad technology :

- Standard range according to DIN28136 dimensions
- Special reactor designs, against customer's specifications
- Reactors can be completely equipped (agitation, sight glasses...)

### DIN 28136 range

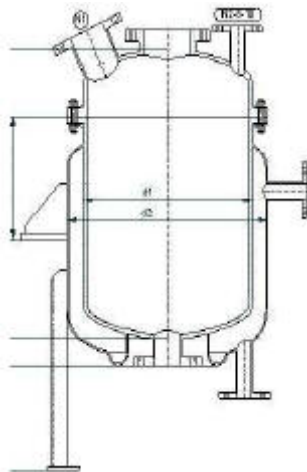

**Type A:**

**Double compartment  
Vessel**

**63L to 6,300L**

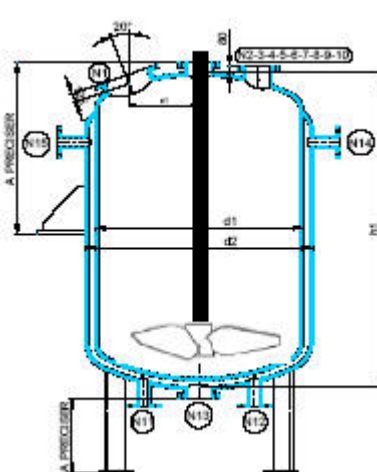

**Type B:**

**Single compartment  
Vessel**

**1,600L to 40,000L**

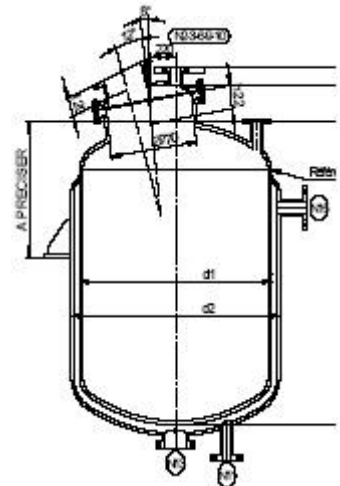

**Type C:**

**Single compartment  
vessel  
with mounted cover**

**1,600L to 40,000L**

## Frequently Asked Questions about CL-CLAD

1. What is the maximum plate dimension?
  - Carbone Lorraine can produce plates up to 4500x2500 mm.  
The standard dimensions will be the same standards as our steel suppliers.
2. Which material can be cladded with CL-CLAD process?
  - At the moment we have developed the CL-CLAD process for Tantalum, Titanium and Zirconium. All these three materials can be cladded on either Carbon Steel and stainless steel.
3. What are the thicknesses limits of reactive metal and base plates?
  - The minimum proposed thickness of reactive metals will be 0.5mm for CL-Clad welded equipments. It is technically feasible to clad thinner layers but then the welding will be difficult. There are no maximum thickness, we can clad any thickness on request. However, it is not useful to increase the thickness for corrosion resistance and the mechanical resistance is made by the base plate.
4. What are the standard thicknesses for Reactive Metal liner?
  - For Tantalum, we will use 0.7mm as a standard. When customer requires bigger thickness for safety, we will propose 1mm.  
For Ti and Zr, 1mm will be the usual thickness.
5. The thicknesses are very small. Is it resistant enough to mechanical shocks?
  - If a tool falls down on a 1mm lining (like explosion clad) it will not resist much more than a 0.5mm lining. Moreover, this risk can exist at the bottom of an equipment but is negligible on the walls. In case of damages, CL-Clad can be repaired with a patch overlapped welded on the damaged surface. 1mm is not necessary for corrosion resistance. If Tantalum starts to be corroded, 1mm thickness will resist only a few minutes more than 0.5mm.
6. Does the cladding resist well to the different thermal elongation between Carbon Steel and Tantalum?
  - CL-Clad is a metallurgical bonding which means that there is an intimate connection between the 2 layers. The Tantalum is a very flexible metal and follows easily the deformation of the base plate. Moreover, the deformations done by the bending test are more constraining than the difference of elongation.
7. Can CL-CLAD equipments be repaired in case of damages on the lining?
  - If a crack appears accidentally on the lining, a patch can be overlapped welded on the damaged surface. For a quick repair, domed washers can be used (same repair parts as for glass lining - Cometec product).
8. Can CL-CLAD Duplex be used for base plate?
  - We cannot use Duplex stainless steel as the base material for Ta CL-CLAD reactor vessels, it is not compatible with the brazing alloy at the required temperature of the process.