

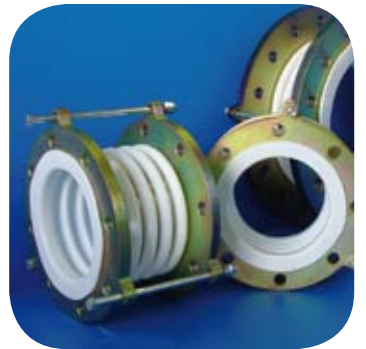

CARBONE LORRAINE CHEMICAL EQUIPMENT DIVISION PTFE Bellows & Compensators

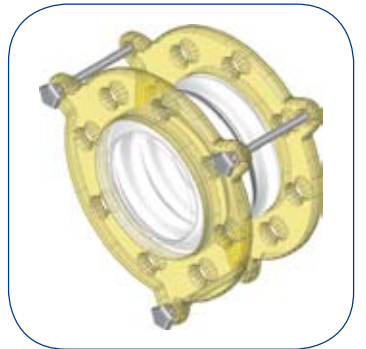
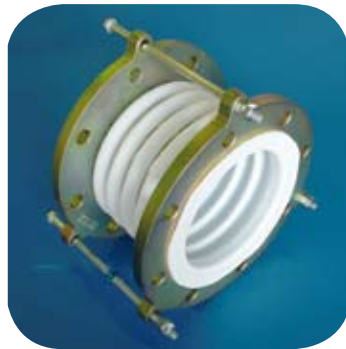

Contents

3 | **Carbone Lorraine**

4 | **Range of Bellows & Compensators**

5 | **References**

6 | **Technical specifications**
7 |

8 | **Bellow flanges**

9 | **Compensator flanges**

10 | **Standard Bellows**
11 |

12 | **Reinforced bellows**
13 |

14 | **Compensators**
15 |

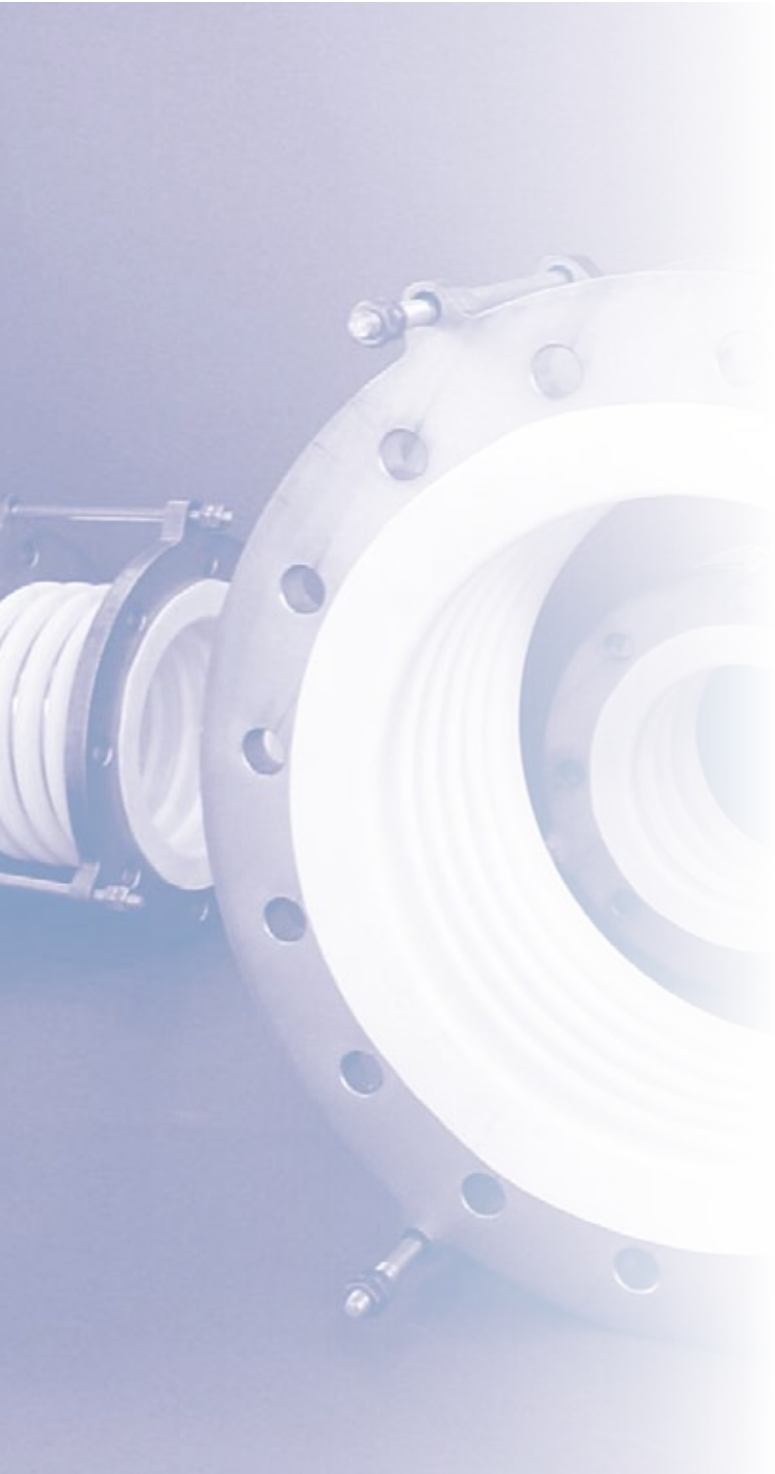

Carbone Lorraine

CARBONE LORRAINE CHEMICAL EQUIPMENT DIVISION MANUFACTURER OF PTFE BELLOWS AND COMPENSATORS

Since 1964, Carbone Lorraine has been a pioneer in the transportation and storage of corrosive fluids. Experience combined with continuous improvement and development of the processes allow CARBONE LORRAINE to offer the widest range in the world: **ARMYLOR®**.

ARMYLOR® includes a wide range of PTFE bellows and compensators offering an exceptional ability to resist corrosion at high temperature, ageing and especially alternate bending.

The performance of these products results from the intrinsic qualities of PTFE and from controlling the processes employed. ARMYLOR® is the ideal answer to the problem of transferring fluids in extreme conditions.

Carbone Lorraine proposes a very wide range of equipment manufactured in various materials to the process industries.

INTERNATIONAL PRESENCE, SHORT DELIVERY TIMES

Based on its international network, Carbone Lorraine has set up a safety stock of semi-finished products in all its subsidiaries allowing a very short delivery.



Range of bellows & compensators

The ARMYLOR® bellows and compensators compensate thermal expansion in pipelines.

They are commonly used to protect fragile equipment (graphite, glass-lined equipment, plastic, etc.) or to absorb vibrations of equipment (pumps, etc.). Additionally ARMYLOR® bellows can be used in extreme corrosive or high-temperature conditions.

CARBONE LORRAINE offers a comprehensive range of expansion joints in ARMYLOR®

STANDARD BELLOWS

207 TYPE



ARMYLOR® type 207 bellows, reinforced by stainless steel rings, which fulfill the requirements of most pressure applications.

REINFORCED BELLOWS

227 TYPE



ARMYLOR® type 227 bellows, reinforced by stainless steel rings and shells, which can withstand higher pressure while keeping their flexibility.

COMPENSATORS

283 TYPE



ARMYLOR® type 283 compensators are externally reinforced by a stainless steel housing and allow operation at very high pressure.

Operation in vacuum for types S207, V207 and V227

All our bellows and compensators are manufactured in accordance with the European Pressure Equipment Directive: PED 97/23 CE

References

Each ARMYLOR® item has a reference which allows it to be defined.

This reference is composed of 13 alphanumeric characters (C1 to C13).

In certain cases, the criteria can be identified by a dash (-) if it corresponds to the standard.

The references of the dimensional tables are those of standard construction.

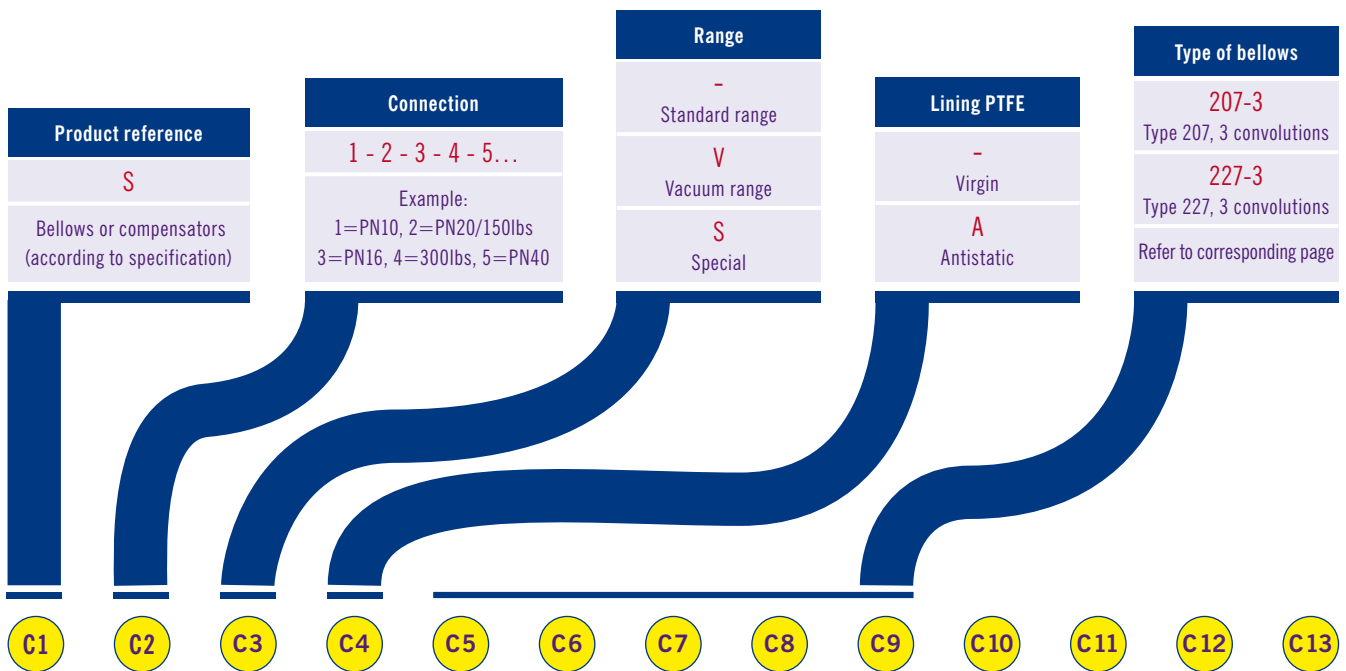

Examples

Bellow, flange connection PN10, type 207, 5 convolutions DN200.

S1--207-5T

Bellows, connection 150 lbs, vacuum range, Antistatic PTFE, type 227, 3 convolutions, DN300, stainless steel flanges.

S2VA227-3V--X

Examples of the reference in a table

References												
C1	C2	C3	C4	C5	C6	C7	C8	C9	C10	C11	C12	C13
S	1	-	-	2	0	7	-	5	T			
S	2	V	A	2	2	7	-	3	V	-	-	X

Diameter		Loose flanges		Steel parts	
For each diameter, corresponds a letter. Refer to the table hereafter		-		-	
For bellows C11= --		0		Standard	
				R Low temperature Carbon steel	
				X Stainless steel	
				S Special	
Codifications REP	Diameter DN (mm)	REP	DN		
H	15	S	150		
J	20	T	200		
K	25	U	250		
L	32	V	300		
M	40	W	350		
N	50	X	400		
O	65	Y	450		
P	80	Z	500		
Q	100	B	600		
R	125				

Technical Specification

Materials

PTFE membranes

The membranes of ARMYLOR® bellows and compensators are manufactured by paste extrusion of fine powder PTFE (polytetrafluorethylene) in accordance with Standard ASTM D 4895. They are then molded under pressure and temperature, ensuring no damage to the material fibers. This technique offers excellent resistance to alternate bending (over 300,000 cycles) associated with very high resistance to permeation.

The PTFE used to produce the membranes complies with ASTM F 1545 the characteristics of which are indicated in the table below.

CARBONE LORRAINE also offers antistatic PTFE membranes.

	Units	
Specific density	g/cm ³	2.14 - 2.19 ASTM D792
Tensile strength	Mpa	210 mini
Elongation at break	%	250 mini

Steel Components

The bellows are connected with carbon steel flanges P265G-H / EN 10 222 or equivalent. On request, flanges can be made in stainless steel.

Protection of steel components: The flanges are protected either zinc plated (standard product) or protected by a layer of zinc ethyl silicate primer compatible with most of the final system. Special painting and other processes are available upon request.

Types	Reinforcement rings	Reinforcement shell	Tie rod	Reinforcement housing
207	Stainless steel 304 L 1.4307		Class 5-6	
204	Hastelloy C276 2.4819		Class 5-6	
224	Hastelloy C276 2.4819	Monel 400 2.4360	Class 5-6	
227	Stainless steel 304 L 1.4307	Stainless steel 304 L 1.4307	Class 5-6	
283				Stainless steel 316 L 1.4404

Inspection and control, certificates

All our products are inspected and controlled by our department in accordance with ISO 9001 quality assurance system. Design and manufacturing control meet the requirement of Pressure Equipment Directive PED 97/23 CE.

Design

Flanges with through holes connect the standard bellows. Sizes are identical whatever the type of drilling of the item. On request, the holes can be tapped.

The compensators are fitted with standard flanges conforming to the type of drilling requested (PN or ANSI).

The flanges have PN 10, PN 16, ANSI 150 lbs or ANSI 300 lbs drilling and others on request.

The maximum operating pressure of the bellows and compensators must be in accordance with the respective pressure/temperature resistance.

Installation procedure

Precautions

Do not remove the wooden plugs until the time of installation; once the plug is removed, great care must be taken to avoid damaging the PTFE.

Cleaning

The bearing surfaces must be carefully cleaned before installation.

Bolt tightening

The installation of ARMYLOR® bellows and compensators does not require any additional gasket, except when connecting to materials of a different nature or in the case of successive assembly and disassembly operations.

Bolt tightening

- Insert the washers.
- Clean and grease the bolts
- Tighten the nuts manually
- Tighten each bolt with a torque wrench, respecting the tightening torques
- Tightening is carried out “crosswise”, like for any flange connecting

The values of tightening torques are available in the assembly instructions delivered with pieces.

They are at-cold values and must always be verified when the equipment is cold, after 24 hours of operation then periodically.

The tightening torque values indicated herein also apply to:

- Class 8.8 steel bolts (rupture resistance 800N/mm, limit of elasticity 640N/mm)
- A screw/nut coefficient of friction of 0.12

Bellows are delivered with limit bolts set at maximum length. Limit bolts must not be removed otherwise bellows performance might be affected..

Bellow Flanges

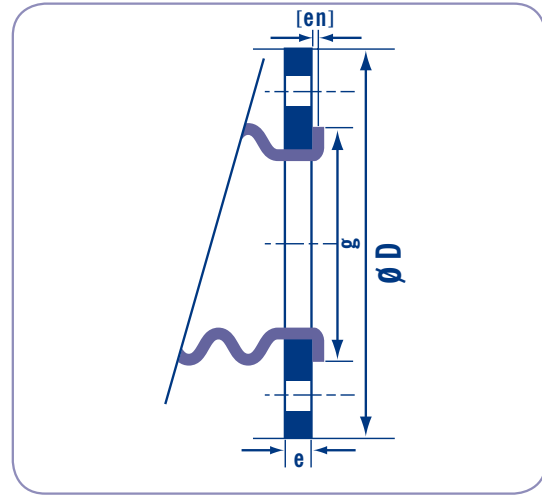
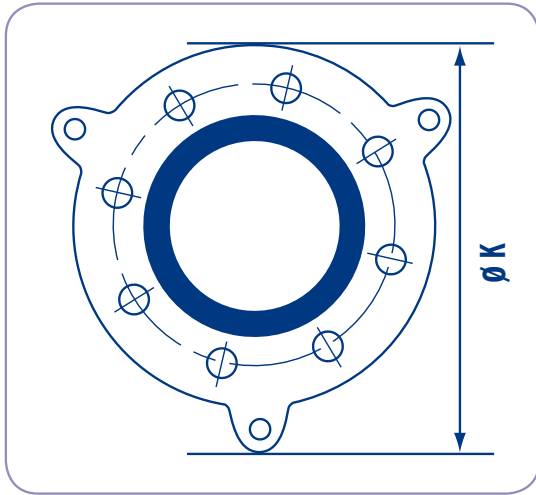

Bellows
Types 207 - 227

DN (mm)	DN (inches)	D (mm)	K (mm)	g (mm)	e (mm)	[en] (mm)	Drilling
20	¾"	105	155	53	12	2.5	X
25	1"	115	160	62	10	2.5	X
32	1¼"	140	190	72	12.5	3	X
40	1½"	150	200	80	12.5	3	X
50	2"	165	220	98	14.5	3.5	X
65	2½"	185	240	118	18.5	3	X
80	3"	200	255	122	18.5	3	H
100	4"	230	290	148	19	3.5	H
125	5"	255	315	174	20.5	4	H
150	6"	285	345	200	21	4	H
200	8"	345	405	256	23	4	H
250	10"	410	470	303	27	4	H
300	12"	485	545	360	27	4	H
350	14"	535	595	402	27	4.5	H
400	16"	600	660	453	27.5	4	H
450	18"	640	695	513	27	3.5	H
500	20"	700	760	564	29	4	H
600	24"	818	885	658	33	4	H



- "X" stands for drillings "on axis / out of axis"
- "H" stands for drillings "on axis / on axis"
- [en] is the nominal thickness of PTFE liners

Compensator flanges

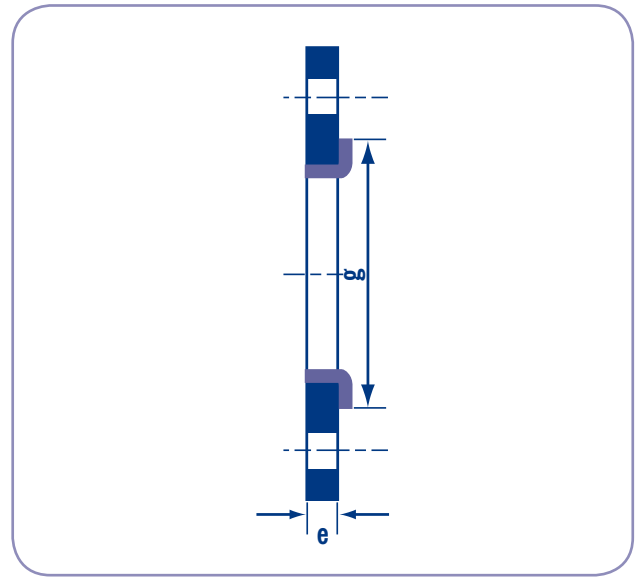
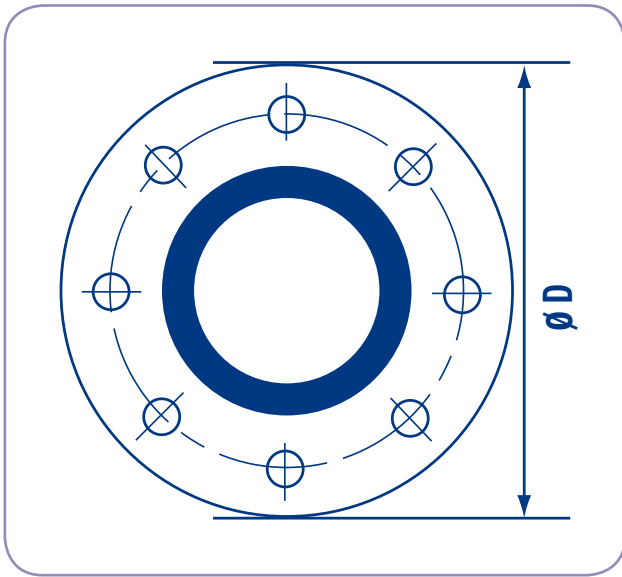

Common characteristics				PN 10		ANSI 150	
DN (mm)	DN (inches)	en (mm)	g (mm)	D (mm)	e (mm)	D (mm)	e (mm)
50	2"	3.5	98	165	22	152.4	24
65	2½"	3	118	185	22	177.8	31
80	3"	9	127	200	22	190.5	31
100	4"	3.5	158	230	22	228.6	31
125	5"	4	188	255	24	254	31
150	6"	4	212	285	24	279.4	31
200	8"	4	268	345	26	342.9	34
250	10"	4	320	410	30	106.4	36
300	12"	4	370	485	30	482.6	38
350	14"	4.5	430	535	30	533.4	41
400	16"	4.5	480	600	30	596.9	42
450	18"	3.5	532	640	30	635	45
500	20"	4	585	700	32	698.5	49
600	24"	4	685	815	36	812.8	53

Standard Bellows Type 207

Ranges G (standard) and V (vacuum)

Characteristics

DN mm	DN inches	Number of Convolutions	L mm	Δx mm	Δy mm	Fx DaN/ mm	Fy DaN/ mm	Weight kg	Availability		References									
									Range G	Range V	C1	C2	C3	C4	C5	C6	C7	C8	C9	C10
20	¾"	3	50	10	8	4.5	2	2.5	✓		S	x	-	-	2	0	7	-	3	J
25	2"	3	50	12	10	4.5	2	2.5	✓		S	x	-	-	2	0	7	-	3	K
		5	75	20	15	4	1.5	2.8	✓		S	x	-	-	2	0	7	-	5	K
32	1¼"	3	50	12	12	5	2.5	3	✓		S	x	-	-	2	0	7	-	3	L
		5	75	20	18	4	2	3.5	✓		S	x	-	-	2	0	7	-	5	L
40	1½"	3	50	12	15	5	2.8	4	✓		S	x	-	-	2	0	7	-	3	M
		5	75	20	20	4	2	4.5	✓		S	x	-	-	2	0	7	-	5	M
50	2"	3	75	15	15	5	4.5	6	✓		S	x	-	-	2	0	7	-	3	N
		5	100	25	20	4	3.5	6.5	✓		S	x	-	-	2	0	7	-	5	N
65	2½"	3	75	22	17	4	5	7	✓	✓	S	x	-	-	2	0	7	-	3	O
		5	100	35	30	3.5	4	7.5	✓		S	x	-	-	2	0	7	-	5	O
80	3"	3	100	25	17	4	6	8	✓	✓	S	x	-	-	2	0	7	-	3	P
		5	125	40	30	3.5	4.5	9	✓		S	x	-	-	2	0	7	-	5	P
100	4"	3	100	25	17	5	9	10	✓	✓	S	x	-	-	2	0	7	-	3	Q
		5	150	40	30	3.5	6	11	✓		S	x	-	-	2	0	7	-	5	Q
125	5"	3	125	28	18	6	11	12	✓	✓	S	x	-	-	2	0	7	-	3	R
		5	175	45	32	4	8	13	✓		S	x	-	-	2	0	7	-	5	R
150	6"	3	150	28	18	10	15	15	✓	✓	S	x	-	-	2	0	7	-	3	S
		5	225	45	32	8	12	17	✓		S	x	-	-	2	0	7	-	5	S
200	8"	3	150	28	20	15	18	20	✓	✓	S	x	-	-	2	0	7	-	3	T
		5	225	45	32	10	15	22	✓		S	x	-	-	2	0	7	-	5	T
250	10"	3	150	28	10	15	20	35	✓	✓	S	x	-	-	2	0	7	-	3	U
		5	225	45	15	10	17	37	✓		S	x	-	-	2	0	7	-	5	U
300	12"	3	150	30	8	15	20	48	✓	✓	S	x	-	-	2	0	7	-	3	V
		5	225	50	10	12	17	50	✓		S	x	-	-	2	0	7	-	5	V
350	14"	3	150	30	6	20	27	57	✓	✓	S	x	-	-	2	0	7	-	3	W
		5	225	50	8	16	23	59	✓		S	x	-	-	2	0	7	-	5	W
400	16"	3	150	30	6	20	27	70	✓	✓	S	x	-	-	2	0	7	-	3	X
		5	225	50	8	16	23	72	✓		S	x	-	-	2	0	7	-	5	X
450	18"	3	150	30	5	25	29	78	✓	✓	S	x	-	-	2	0	7	-	3	Y
		5	225	50	7	20	24	80	✓		S	x	-	-	2	0	7	-	5	Y
500	20"	3	150	30	5	30	35	86	✓	✓	S	x	-	-	2	0	7	-	3	Z
		5	225	50	7	25	30	89	✓		S	x	-	-	2	0	7	-	5	Z
600	24"	3	175	30	4	30	35	125	✓	✓	S	x	-	-	2	0	7	-	3	B
		5	250	50	6	25	30	130	✓		S	x	-	-	2	0	7	-	5	B



L is the dimension to be obtained at Installation (neutral length)

F_x and **F_y** are the forces of compression and offset in daN for an axial movement $\Delta x = 1$ mm or a misalignment $\Delta y = 1$ mm

C2: x on the column must be filled in according to your specifications: 1 = PN10, 2 = 150 lbs, etc.

C3: - (here in standard). The vacuum option V is only available for 3 convolutions bellows

Range

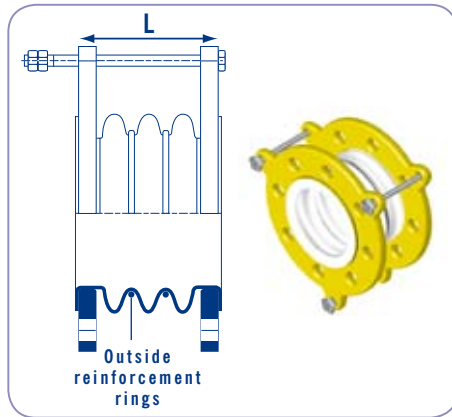

BELLOWS STANDARD RANGE G207
3 and 5 convolutions

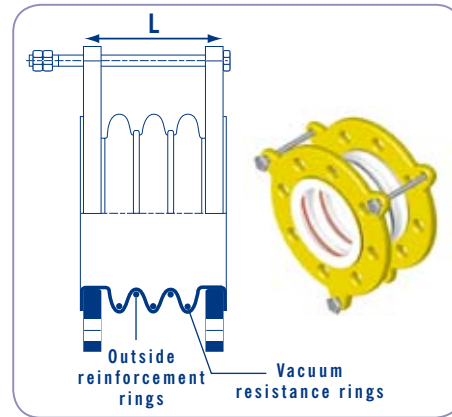

BELLOWS RANGE VACUUM V207
Available only with 3 convolutions

The performance curves

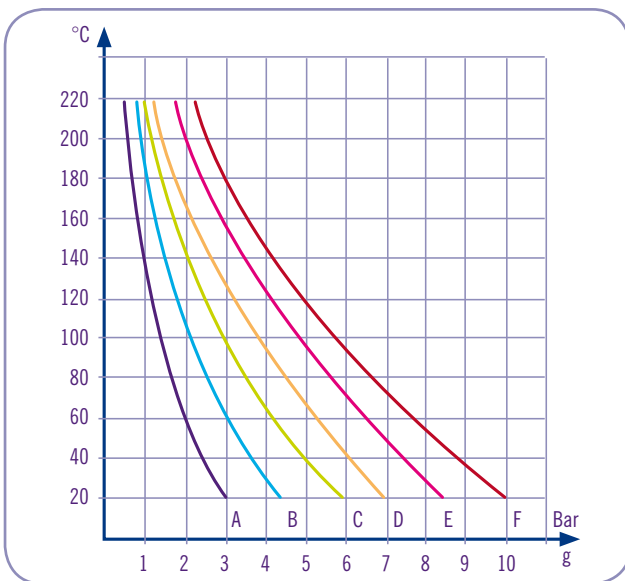

PRESSURE RESISTANCE
Ranges G (standard) and V (Vacuum) – 3 convolutions

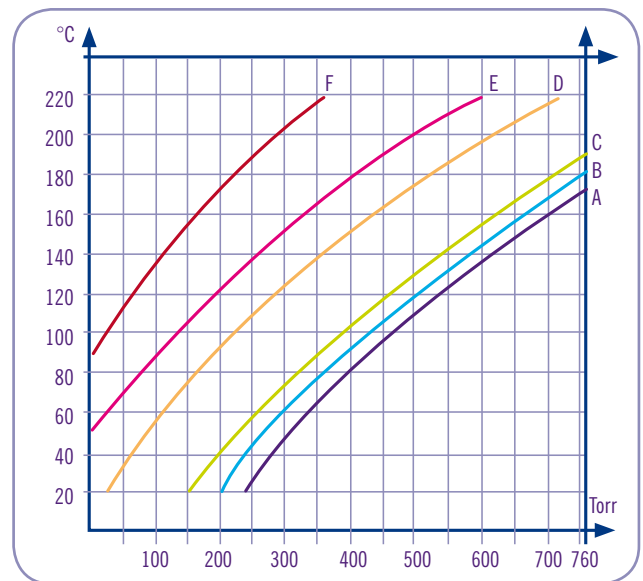

VACUUM RESISTANCE
Range G (standard)



- For G 5 convolutions standard bellows, the values of vacuum and pressure resistance must be multiplied by 0.5
- The vacuum resistance of G207 bellows from DN20 to DN50 together with V207 bellows is 2 Torr up to 180°C
- DN750, 900 and 1050 are available upon request

For operation in corrosive environment, Carbone Lorraine offers serie 204 bellows with Hastelloy C 276 rings (nickel alloys). The characteristics and sizes of the type 204 bellows are identical to those of type 207

Curves	DN (mm)
A	500 & 600
B	400 & 450
C	300 & 350
D	200 & 250
E	100 & 150
F	25 à 80

Reinforced bellows Type 227

Range G (standard) and V (Vacuum)

Characteristics

DN mm	DN inches	Number of Convolutions	L mm	Δx mm	Δy mm	Fx DaN/ mm	Fy DaN/ mm	Weight kg	Availability		References									
									Range G	Range V	C1	C2	C3	C4	C5	C6	C7	C8	C9	C10
25	1"	3	50	7	4	4.5	2	2.5	✓		S	x	-	-	2	2	7	-	3	K
32	1¼"	3	50	7	4	5	2.5	3	✓		S	x	-	-	2	2	7	-	3	L
40	1½"	3	50	7	5	5	2.8	4	✓		S	x	-	-	2	2	7	-	3	M
50	2"	3	75	8	5	5	4.5	6.5	✓		S	x	-	-	2	2	7	-	3	N
65	2½"	3	75	10	5	4	5	7.5	✓	✓	S	x	-	-	2	2	7	-	3	O
80	3"	3	100	15	8	4	6	8.5	✓	✓	S	x	-	-	2	2	7	-	3	P
100	4"	3	100	15	8	5	9	11	✓	✓	S	x	-	-	2	2	7	-	3	Q
125	5"	3	125	20	10	6	11	13	✓	✓	S	x	-	-	2	2	7	-	3	R
150	6"	3	150	28	10	10	15	16	✓	✓	S	x	-	-	2	2	7	-	3	S
200	8"	3	150	28	10	15	18	21	✓	✓	S	x	-	-	2	2	7	-	3	T
250	10"	3	150	28	10	15	20	36	✓	✓	S	x	-	-	2	2	7	-	3	U
300	12"	3	150	30	8	15	20	49	✓	✓	S	x	-	-	2	2	7	-	3	V
350	14"	3	150	30	6	20	27	58	✓	✓	S	x	-	-	2	2	7	-	3	W
400	16"	3	150	30	6	20	27	72	✓	✓	S	x	-	-	2	2	7	-	3	X
450	18"	3	150	30	5	25	29	80	✓	✓	S	x	-	-	2	2	7	-	3	Y
500	20"	3	150	20	5	30	35	89	✓	✓	S	x	-	-	2	2	7	-	3	Z
600	24"	3	175	20	4	30	35	130	✓	✓	S	x	-	-	2	2	7	-	3	B



For operation in corrosive environment, CARBONE LORRAINE offers serie 224 bellows with HASTELLOY C 276 (nickel alloy rings) and MONEL 400 shells
The characteristics and the dimensions of type 224 bellows are identical to those of 227



Legend of datasheet



L is the dimension to be obtained during installation (neutral length)



Fx and Fy are the forces of compression and offset in daN for an axial movement $\Delta x = 1$ mm or a misalignment $\Delta y = 1$ mm



C2: x on the column must be filled in according to your specifications: 1 = PN10, 2 = 150 lbs, etc.



C3: - (here in standard). The vacuum option V is only available for 3 convolutions bellows

Range

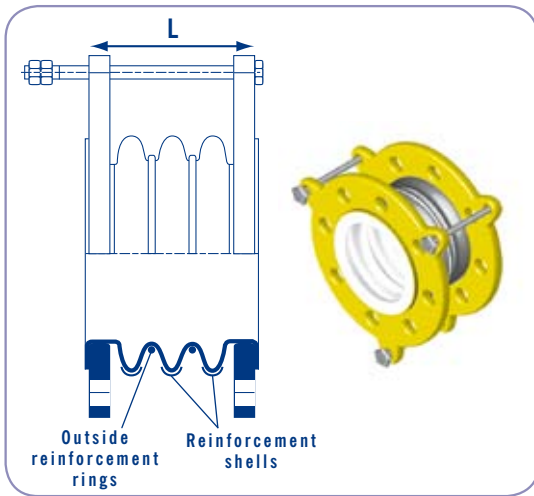

BELLOW STANDARD RANGE G227
3 convolutions only

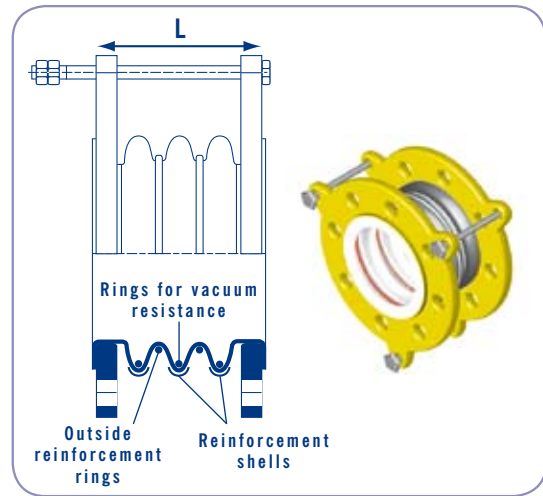

BELLOW RANGE VACUUM V227
3 convolutions only

Performance curves

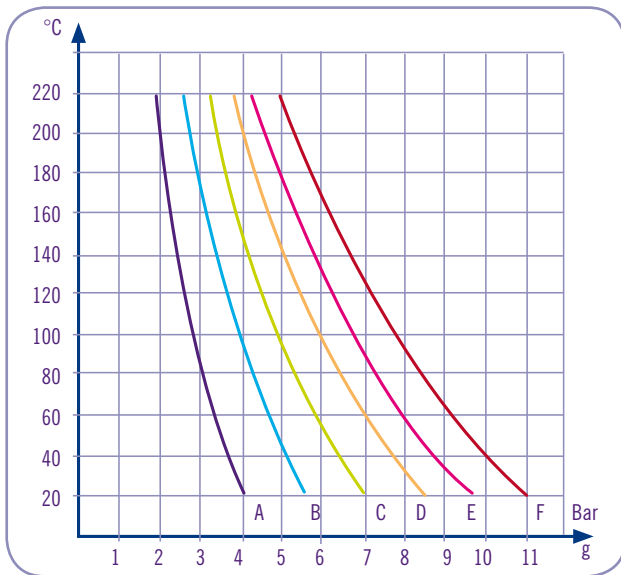

PRESSURE RESISTANCE
Range G (standard) and V (Vacuum) – 3 convolutions

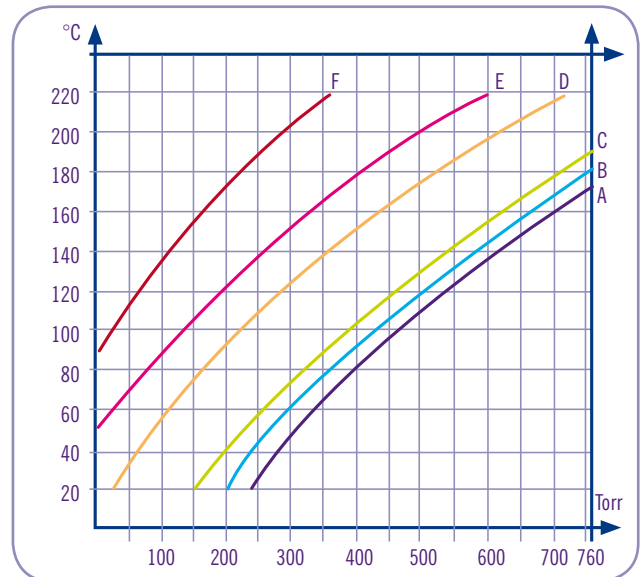

VACUUM RESISTANCE
Range G (standard)



- G Bellows from DN25 to DN50 withstand vacuum resistance of 2 Torr at 180°C
- The vacuum resistance of V227 bellows is 2 Torr up to 180°C

Curves	DN (mm)
A	500 & 600
B	400 & 450
C	300 & 350
D	200 & 250
E	100 & 150
F	25 à 80

Compensators Type G 283

The characteristics

In contrast to bellows, Carbone Lorraine compensators are not equipped with limit bolts.

DN mm	DN inches	L mm	$\pm \Delta x$ mm	$\pm \Delta y$ mm	Fx DaN/ mm	Fy DaN/ mm	Weight kg	References									
								C1	C2	C3	C4	C5	C6	C7	C8	C9	C10
50	2"	150	3.5	45	23	24	5.5	S	x	-	-	2	8	3	-	-	N
65	2½"	150	4	45	22	44	6.5	S	x	-	-	2	8	3	-	-	O
80	3"	150	4	1	39	110	7.5	S	x	-	-	2	8	3	-	-	P
100	4"	150	5	1	34	140	8.5	S	x	-	-	2	8	3	-	-	Q
125	5"	150	5	1	74	430	11	S	x	-	-	2	8	3	-	-	R
150	6"	195	11	2	38	140	13	S	x	-	-	2	8	3	-	-	S
200	8"	245	14	3	38	170	20	S	x	-	-	2	8	3	-	-	T
250	10"	400	17	3	50	190	27	S	x	-	-	2	8	3	-	-	U
300	12"	400	24	6	40	37	41	S	x	-	-	2	8	3	-	-	V
350	14"	400	39	9	21	53	55	S	x	-	-	2	8	3	-	-	W
400	16"	400	42	9	27	53	75	S	x	-	-	2	8	3	-	-	X
450	18"	400	36	7	25	80	80	S	x	-	-	2	8	3	-	-	Y
500	20"	400	36	6	31	110	100	S	x	-	-	2	8	3	-	-	Z
600	24"	400	36	6	38	160	120	S	x	-	-	2	8	3	-	-	B



Legend of datasheet



C2 : x on the column must be filled in according to your specifications: 1 = PN10, 2 = 150 lbs, etc.

Range

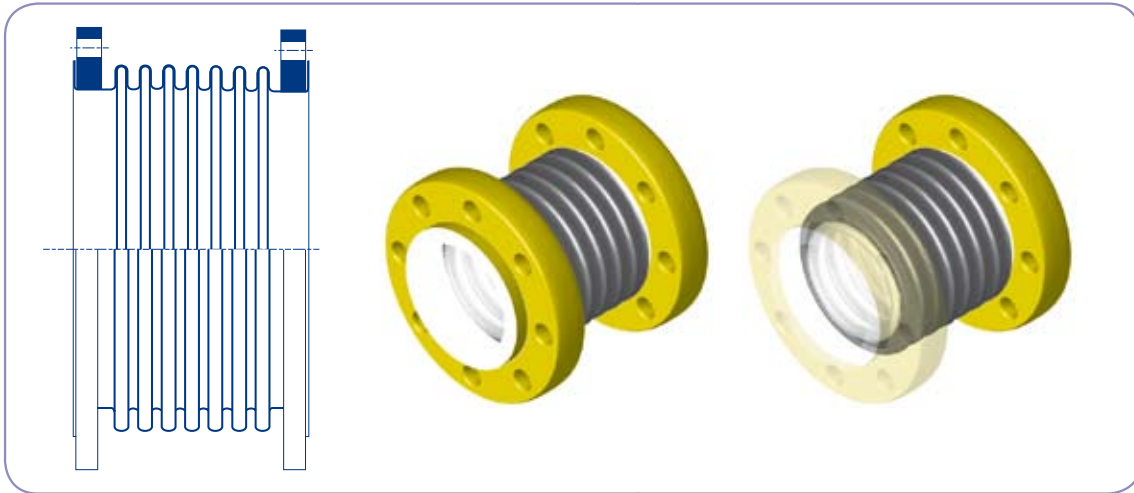

COMPENSATOR G283

Performance Curves

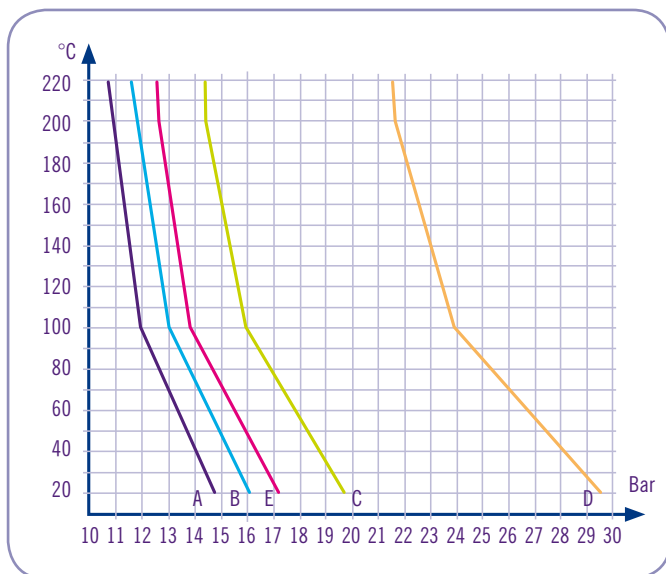

PRESSURE RESISTANCE

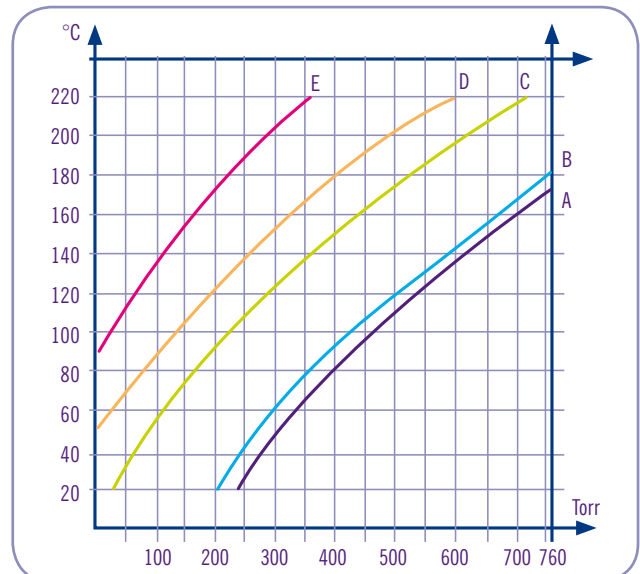

VACUUM RESISTANCE



Warning !! Flange rating must be in accordance with the operating pressure

Curves	DN (mm)
A	500 & 600
B	300 & 450
C	200 & 250
D	100 & 150
E	50 & 80

CARBONE LORRAINE CHEMICAL EQUIPMENT DIVISION

Worldwide presence with several manufacturing sites and workshops close to our customers

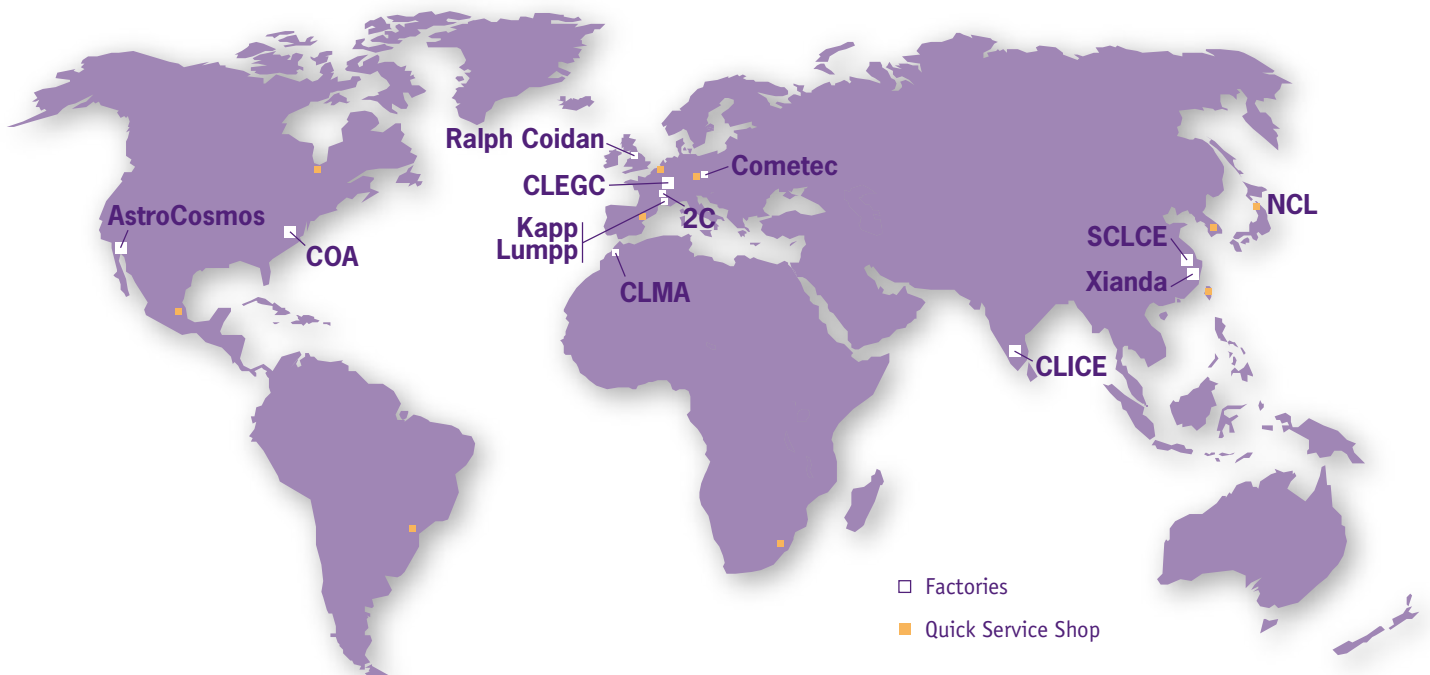

B16_1_E - YSDJN COMMUNICATION www.yan.fr

CLEGC **SCLCE** **COA** **NCL** **CLICE** **LUMPP** **CLMA**

CARBONE LORRAINE EQUIPEMENTS GÉNIE CHIMIQUE

SHANGHAI CARBONE LORRAINE CHEMICAL EQUIPMENT

CARBONE OF AMERICA

NEPPON CARBONE LORRAINE

CARBONE LORRAINE INDIA CHEMICAL EQUIPMENT

CARBONE LORRAINE MAROC



CARBONE LORRAINE CED

1 rue Jules Ferry F-54530 PAGNY-SUR-MOSELLE • Tel.: +33 (0)3 83 81 60 81 Fax: +33 (0)3 83 81 50 75 • Email : info@carbonelorraine.com

www.chem.carbonelorraine.com

